

SLP85xD Load Cells



SLP85xD Load Cells

Direct PLC Connectivity

Diagnostic Features

Robust Design

Easy-to-Clean

Designed for Automated Weighing
for Fast Filling Processes

METTLER TOLEDO

Fast, Compact & Intelligent Weighing High Productivity in Harsh Environments

Future production requires intelligent and high performance measuring technology. SLP85xD load cells are designed for fast filling of liquid food and chemicals, as well as for sorting & grading applications, including completeness control.

Compared to volumetric measuring methods, weighing is the most accurate technology to determine the amount of high viscose materials. SLP85xD family load cells are ideal for integrating into linear or rotary multi-head filling machines. Typical food products that can be filled are fruit juices, edible oil, low fat emulsions, like sauces, and heterogeneous products, such as yogurt. Sanitary aspects are also important design criteria in food processing. The filling of chemicals, lubricants and cosmetic products can also be filled at a very high accuracy.



PROFINET[®]
INDUSTRIAL ETHERNET



PROFIBUS[®]
PROCESS FIELD BUS



EtherNet/IP[™]

Plug & Communicate with Most Common PLC Systems

SLP85xD is dedicated for use in automation. Connectivity via PROFIBUS DP, EtherNet/IP or PROFINET IO RT is incorporated in the space saving, compact unit.



Comprehensive Overload Protection Assures High Uptime

SLP85xD family load cells have a robust, integrated overload protection, which protects the load cell against overload forces up to 100 kg in upward and downward directions.



Fast Weighing and Data Transfer to PLC

Up to 1200 filtered weight values per second can be transmitted from the load cell directly to the PLC. This data allows the control system to perform sorting & grading processes, including completeness control.

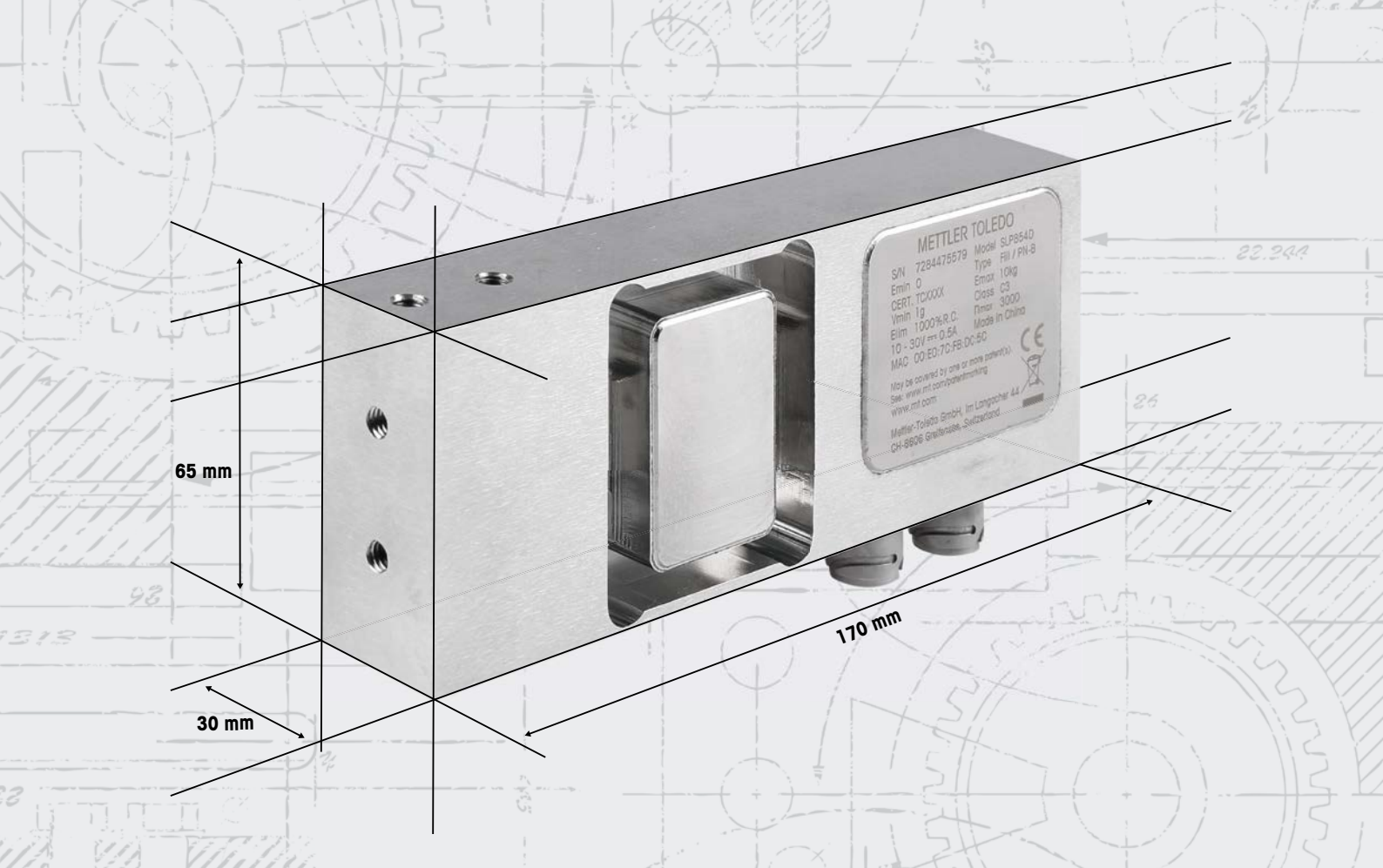

Diagnostic Features for Quality and Performance Assurance

The load cell monitors its status and forwards information to the PLC in case of an issue which might cause unreliable weight values or a failure in the future. Three LEDs indicate this information directly on the load cell.



Integrated Filling Control with Digital In-/Outputs

SLP85xD offers the possibility to control filling processes autonomously with digital I/O's for steering the dosing device. This ensures high performance filling and reduces the reaction time.

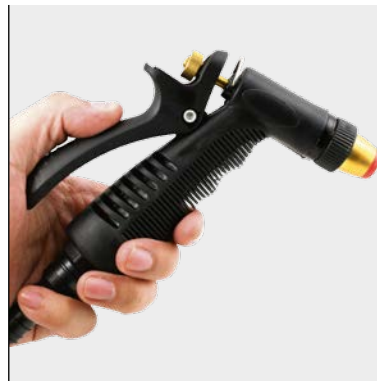

Cleaning with High-Pressure Water Jets and Chemicals

In accordance with IP69K, the robust stainless steel load cell body and high ingress protection with hermetic sealing permit aggressive disinfection procedures which are typical in the food processing industry.

Parameter	SLP850D	SLP852D	SLP854D
Integrated application	None	Filling	Filling
Digital IO	None	None	3 inputs, 5 outputs
Maximum capacity	10 kg/20 kg		
OIML Class	C3		
Default readability	1 g/2 g		
Repeatability error	≤ 0.01% of the applied load		
Combined error (non-linearity + hysteresis)	≤ 0.02% of the maximum capacity		
Power supply voltage	10 ... 30 V DC		
Interfaces	EtherNet/IP PROFINET IO RT PROFIBUS DP		
IP rating	IP68/IP69K		
Materials	Counterforce: Stainless steel 17-4 PH Connector: Stainless steel SUS304 Cable: PU		
Overloadprotection	Central load: 100 kg Side load: 15 kg/30 kg at maximum platter size		
Maximum platter size	400 × 400 mm		
Maximum update rate	Up to 1200 filtered and compensated weight values/second		

EtherNet/IP™

PROFINET

PROFIBUS

Convenient Service Tool Speeds up Commissioning

The APW-Link™ PC based software can be used for simple configuration purposes. The following operations can be performed:

- Configuration of weighing parameters
- Optimization of filter settings
- Calibration & adjustment
- Observe weighing data on a graph and export to a spreadsheet for further processing

APW-Link™ can be downloaded from www.mt.com/apw-link

For more information: www.mt.com/SLP85xD



www.mt.com/SLP85xD

For more information

Mettler-Toledo GmbH

CH-8606 Greifensee
Switzerland

Tel. + 41 44 944 22 11

Fax + 41 44 944 30 60

Subject to technical changes
© 05/2016 Mettler-Toledo GmbH
30302324/ MarCom Industrial



Quality certificate. Development, production and testing according to ISO 9001.



Environmental management system according to ISO 14001.



«European conformity». The CE conformity mark provides you with the assurance that our products comply with the EU directives.